

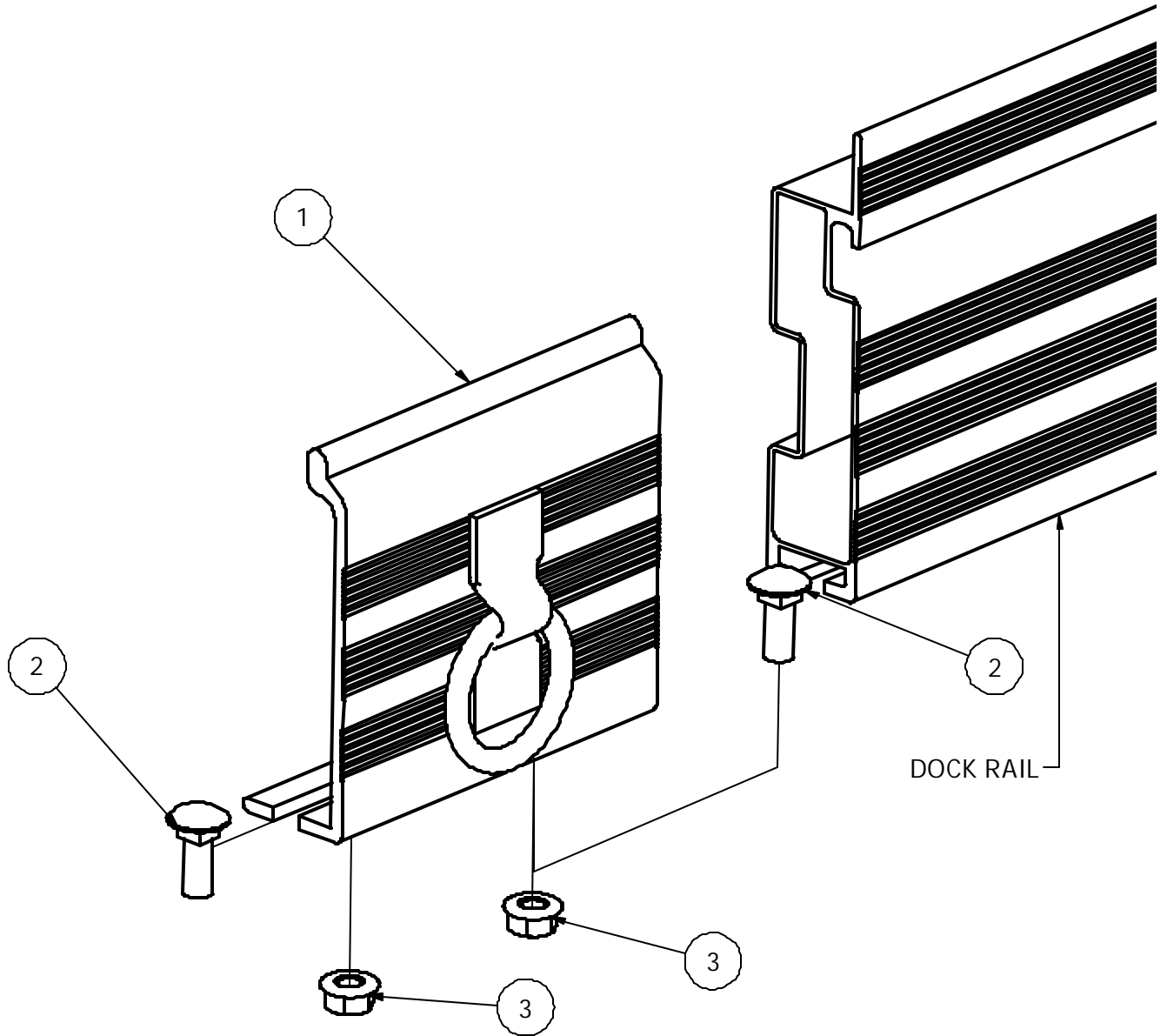

# VM-012-A MOORING RING

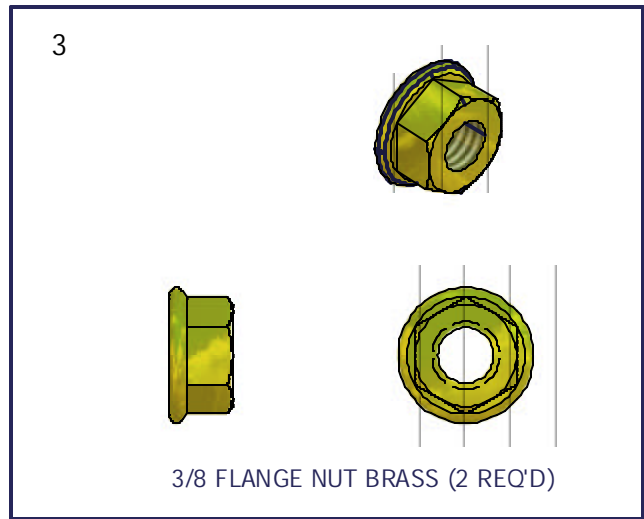

PARTS LIST			
ITEM	QTY	PART NUMBER	DESCRIPTION
1	1	VM-012-A	MOORING RING
2	2	HD-00059	3-8 X 1 SS CAR
3	2	HD-00056	3/8 BRASS FLANGE NUT

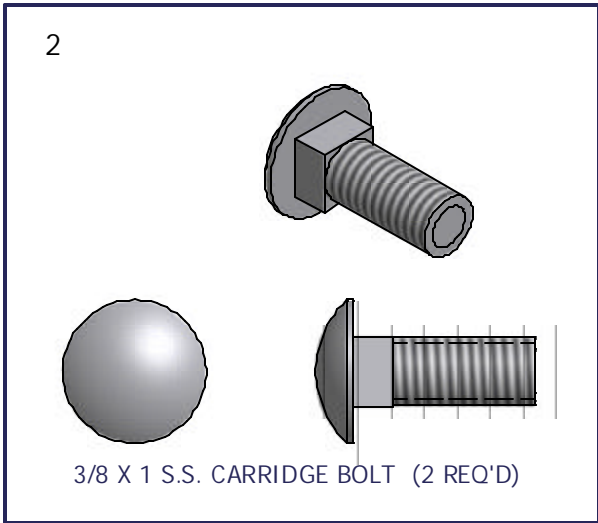

### Installation procedure

The following tool will be needed: 9/16" wrench

1. Insert head of carriage bolts into raceway on the underside of rail and slide to desired location on dock (**per diagram A**).
2. Slide bracket into dock rail and put carriage bolts into bracket and attach flange nuts (**per diagram B**).
3. Take 9/16 wrench and tighten flange nut.

